

Connecting strengths

Plug into the new PPA
Ultramid® Advanced T2000

 **BASF**

We create chemistry



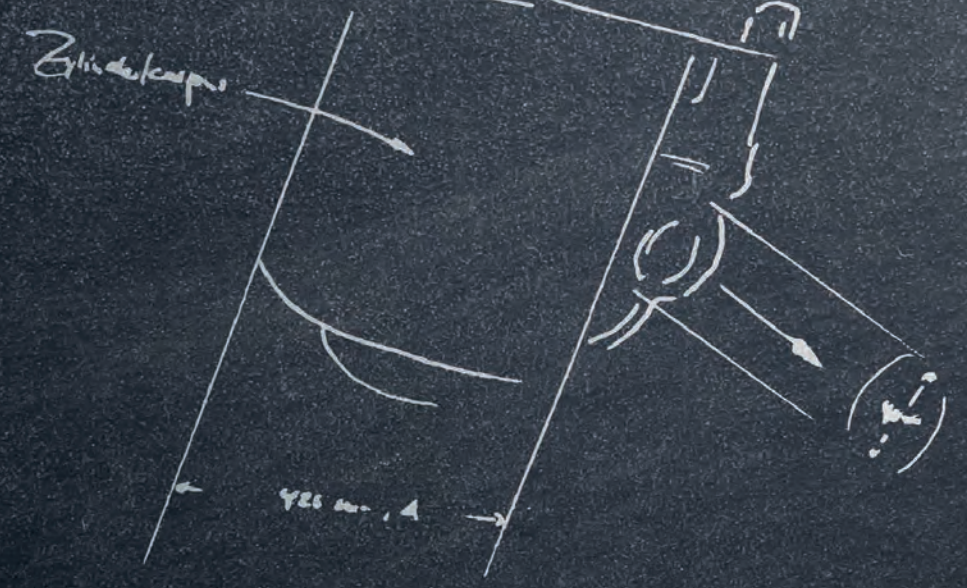

Ultramid® Advanced T2000

CONTENTS

THE NEW PPA ULTRAMID® ADVANCED T2000 – CONNECTING STRENGTHS	4-5
KEY PROPERTIES	6-9
COMPOUND PORTFOLIO TAILORED FOR SPECIFIC E&E REQUIREMENTS	10-11
ULTRAMID® ADVANCED T2000 FOR THE ELECTRICAL AND ELECTRONICS INDUSTRY	12-13
ULTRAMID® ADVANCED T2000 FOR THE AUTOMOTIVE AND TRANSPORTATION INDUSTRY	14-15
EASY PROCESSING	16
VERSATILE POST-PROCESSING	17
PRECISE PART DESIGN WITH ULTRASIM®	18

The new PPA Ultramid® Advanced T2000

CONNECTING STRENGTHS

In the electrical and electronics (E&E) industry, the trend for further miniaturization drives the development of the next generation of high-performance parts, especially in the connector market. Using today's standard materials, part performance challenges require dielectric and mechanical strength in very demanding conditions, which are difficult to achieve with current materials. Furthermore, good mechanical properties at high temperatures and resistance to humid environments or chemicals call for new plastic materials as an alternative for further replacing metal to save weight.

In order to connect these needs with an appropriate solution, BASF is now extending its polyphthalamide (PPA) portfolio with Ultramid® Advanced T2000 – a new compound group based on the polyphthalamide 6T/66. Ultramid® Advanced T2000 combines excellent mechanical with dielectric strength at high temperatures - a combination which is particularly needed for electrical and electronic connectors. Due to its partially aromatic chemical structure, Ultramid® Advanced T2000 is a versatile alternative to metal in specific humid conditions.

With this excellent property profile as well as BASF's long application experience and profound technical expertise, Ultramid® Advanced T2000 is the solution for connecting mechanical and dielectric strength in E&E and automotive applications.

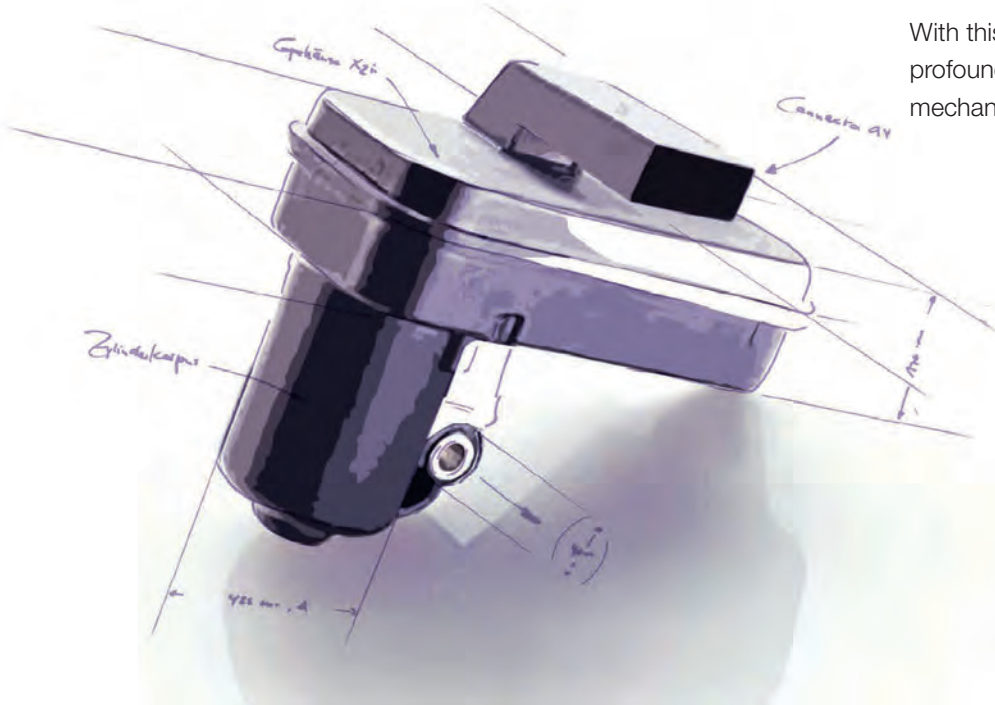

Einführrohr

126

chemical resistance
low water uptake
dimensional stability
hydrophobicity

Unpolarity

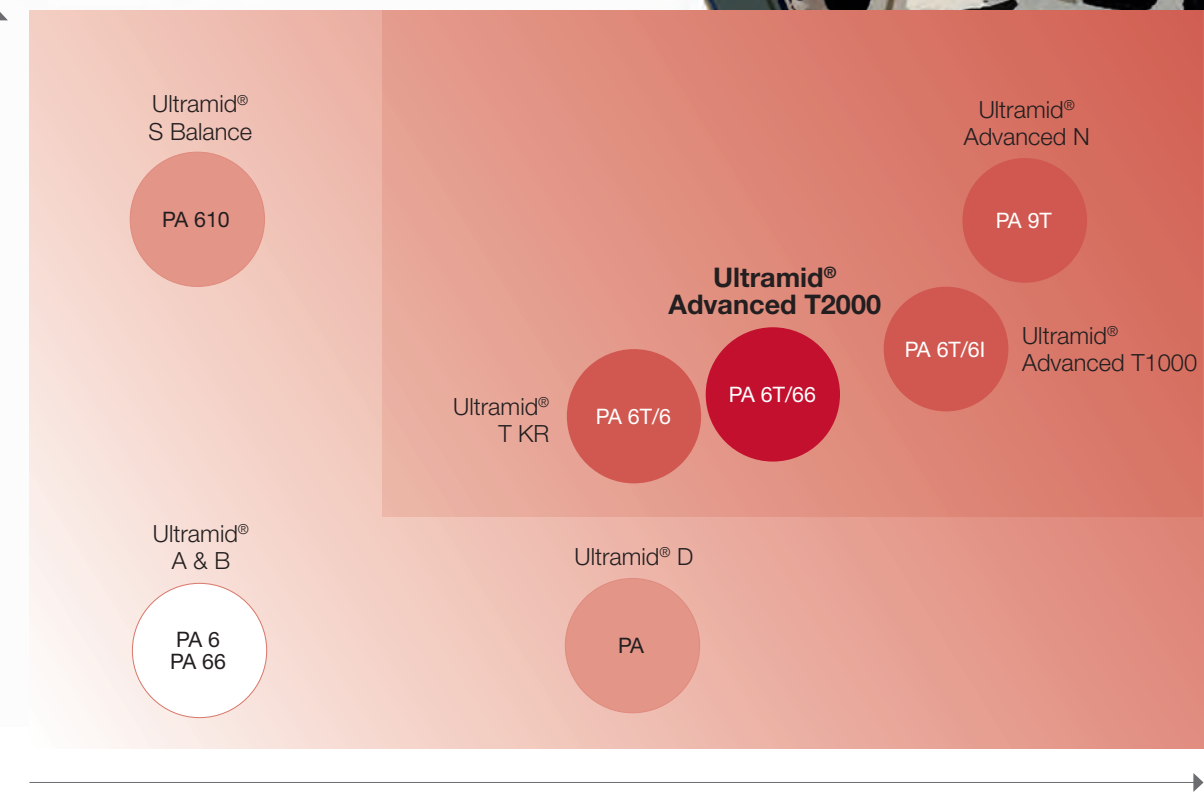

Fig. 1: Performance of different Ultramid® grades at elevated temperatures and in humid conditions

Conditioned glass transition temperature

Ultramid® Advanced T2000

KEY PROPERTIES

Ultramid® Advanced T2000 offers decisive advantages regarding mechanical properties and resistance to humidity as well as for processing.

Excellent mechanical, electrical and thermal properties:

- High strength, stiffness and resistivity with superior mechanical and electrical properties compared to standard polyamides such as PA 6 or PA 66 over the complete range of application temperatures, both dry and in conditioned state (figs. 2 and 3)
- Improved impact strength above market benchmark for PA 6T/66, as well as on par with standard PA 66 (figs. 4 and 5)
- High melting point (310 °C) and heat deflection temperatures of >280 °C (HDT-A) for lead-free soldering without deformation

Outstanding resistance to humidity:

- Lower water uptake than standard aliphatic polyamides such as PA 6 or PA 66 resulting in high dimensional stability, and small impact on properties (fig. 6).

Efficient processing:

- Significantly higher flowability compared to other high-temperature polyamides without compromising flexibility or toughness
- Several post-processing options such as welding with other Ultramid® Advanced T2000 grades, polyamides or PPAs in general, and laser marking

For a broad application range, BASF developed several grades of Ultramid® Advanced T2000 with reinforcement levels ranging from 30 % up to 50 % glass fibers. Depending on the requirements of individual applications, different heat stabilizers are available.

With these properties, Ultramid® Advanced T2000 can be applied in parts that require high and constant stiffness and strength over a broad temperature range in combination with resistance to heat and humidity.

Such applications can be found in mainly:

- the E&E connector industry where high resistivity, mechanical strength and resistance to humidity are required
- the transportation industry where materials must remain strong in whatever temperatures or environments



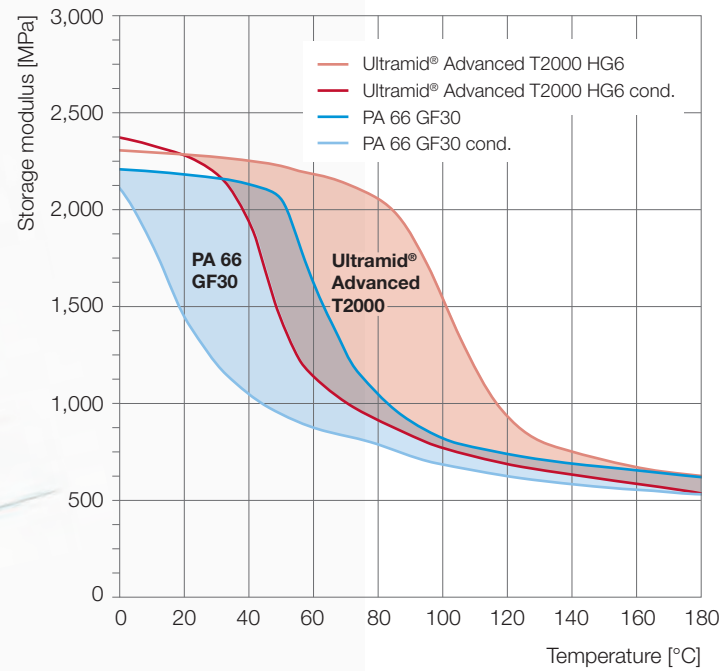
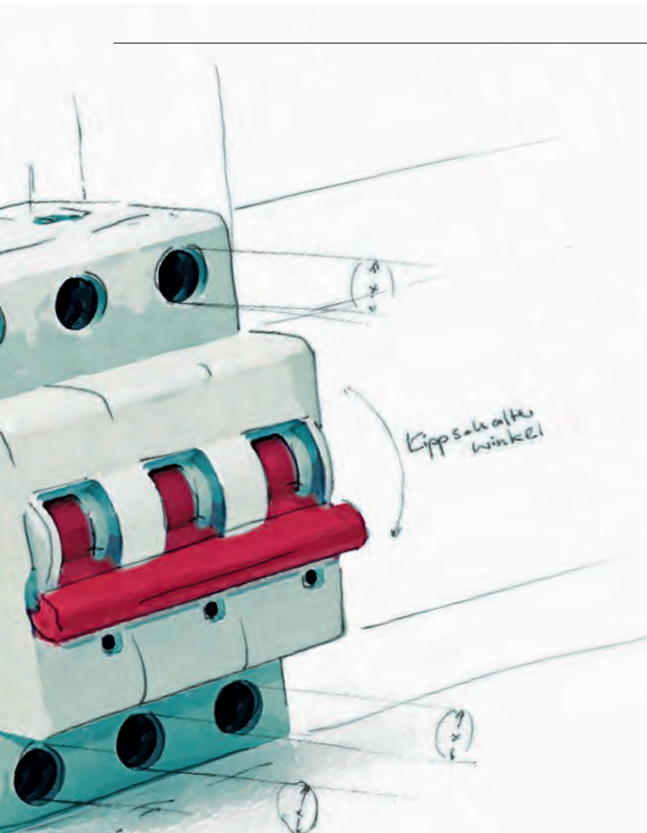

Fig. 2: Ultramid® Advanced T2000 with 30 % glass fiber reinforcement displays superior mechanical and electrical properties compared to standard polyamides such as PA 6 and PA 66 over the complete range of application temperatures, both dry and in conditioned state.

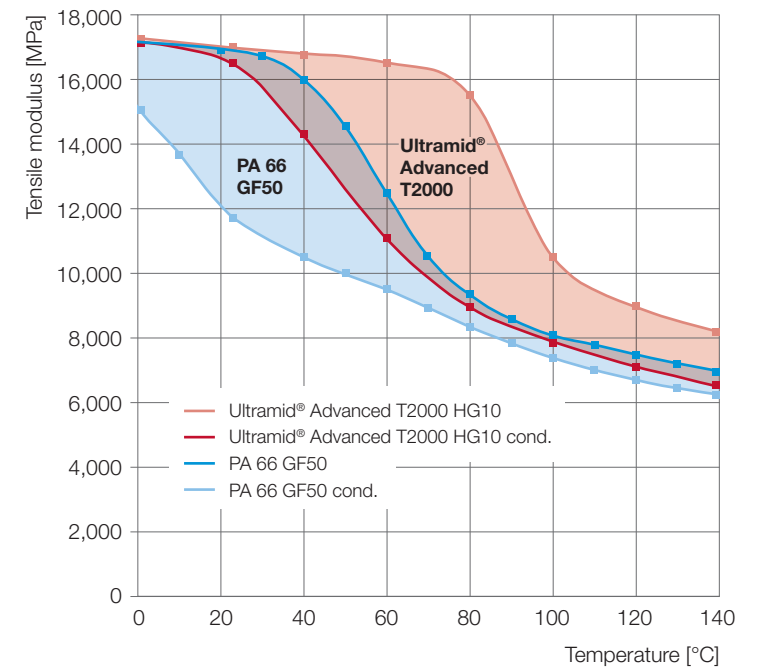

Fig. 3: At higher glass fiber reinforcements (50 %), Ultramid® Advanced T2000 outperforms standard polyamides with constant mechanical properties over a much broader temperature range.

Ultramid® Advanced T2000

KEY PROPERTIES

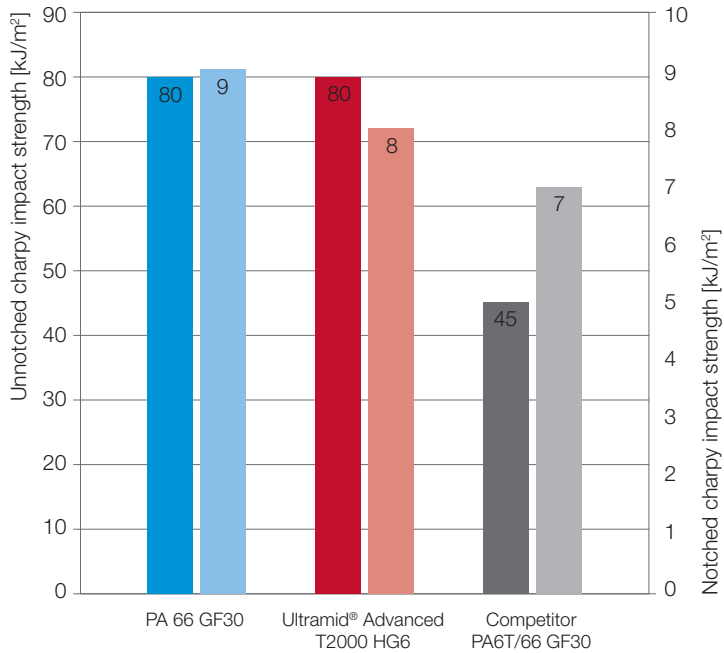

Fig. 4: Ultramid® Advanced T2000 with 30 % glass fiber reinforcement shows comparable impact strength to standard PA 66, while exceeding other PA 6T/66 grades on the market.

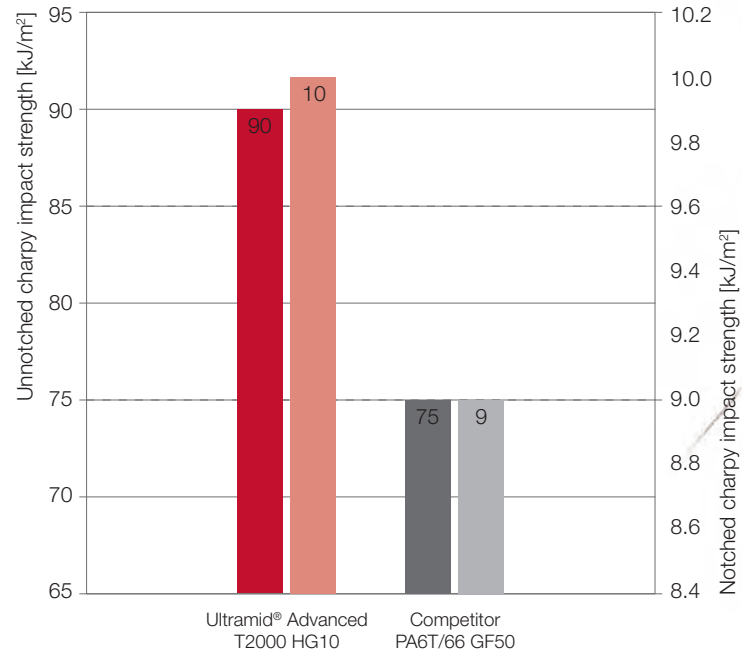
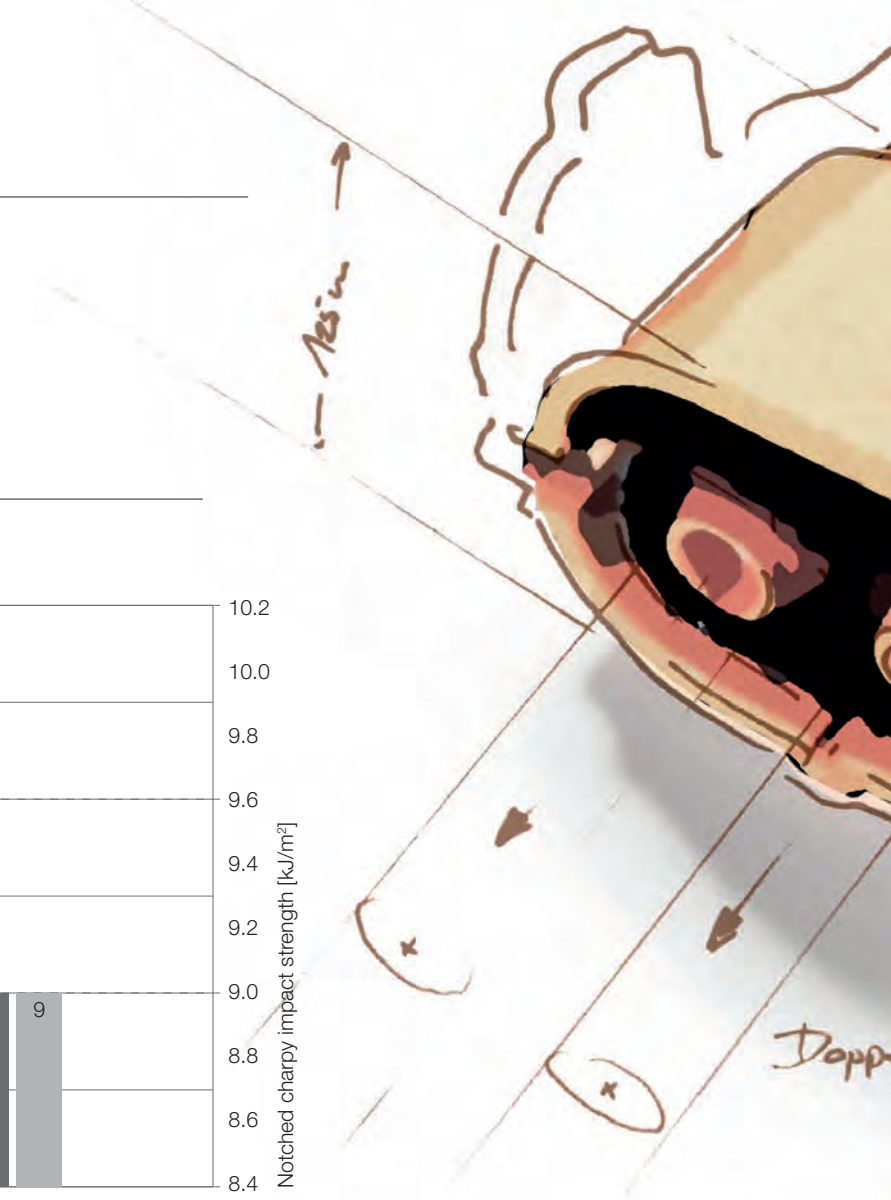
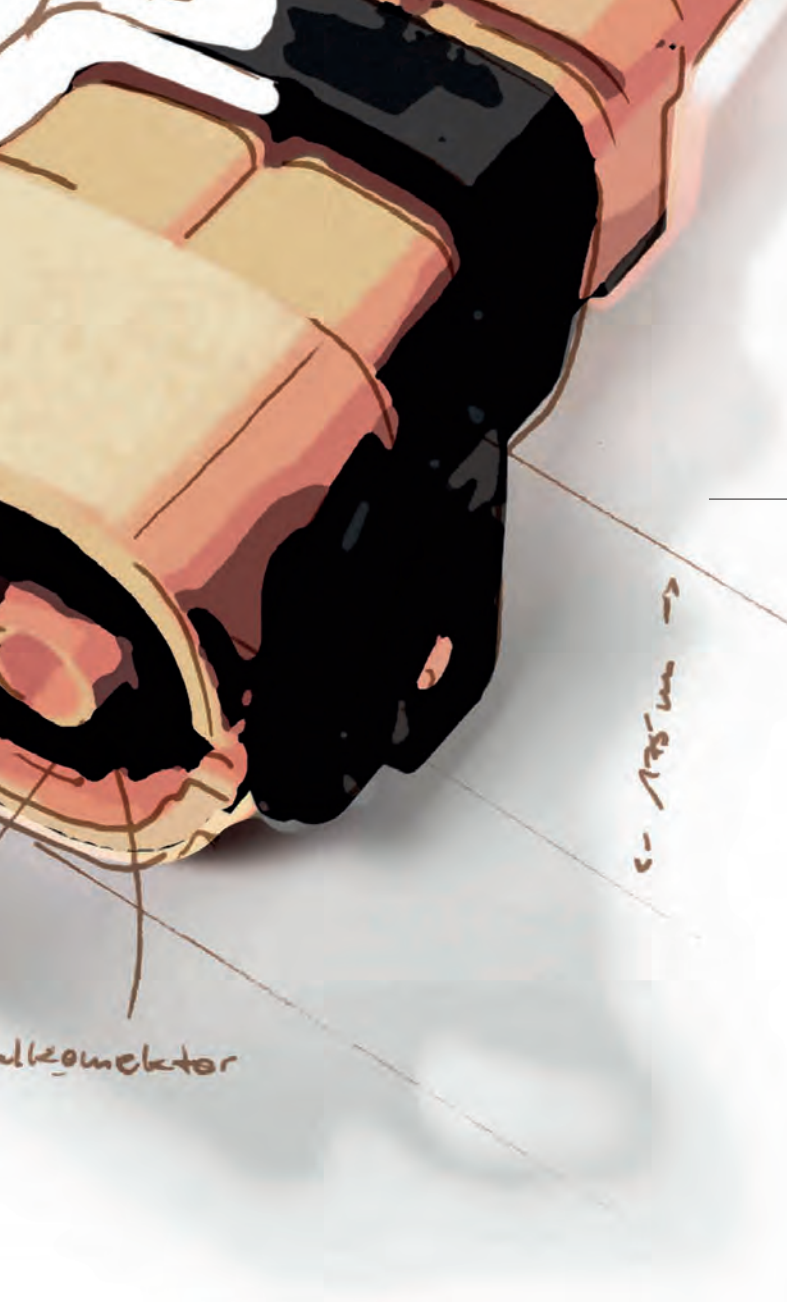

Fig. 5: With 50 % glass fiber reinforcement, Ultramid® Advanced T2000 displays the optimal impact strength compared to other PA 6T/66 grades on the market.





Many of the general advantages of the Ultramid® product family are also typical properties of Ultramid® Advanced T2000:

- good heat stability
- relatively good resistance after storage in water due to lower and slower water uptake compared to PA 66 (fig. 6).

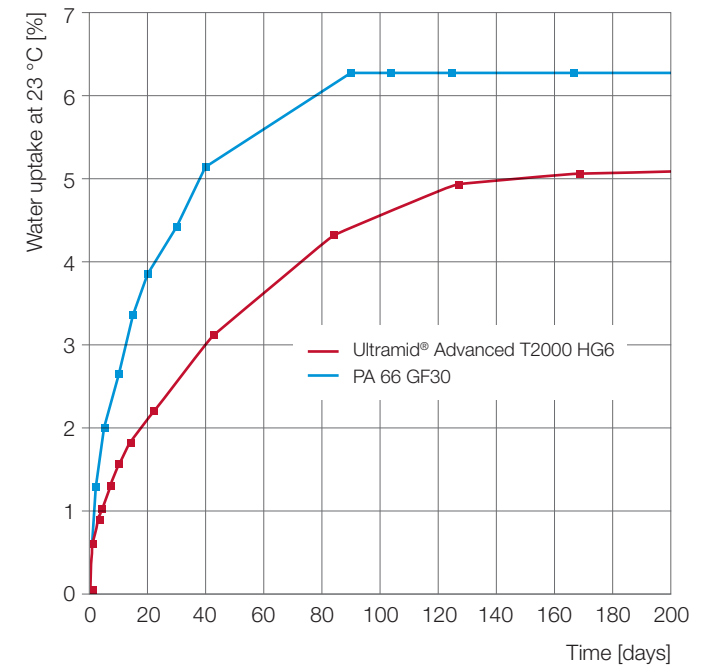

Fig. 6: Ultramid® Advanced T2000 with 30 % glass fiber reinforcement exhibits slightly lower and slower water uptake than aliphatic PA compounds resulting in higher dimensional stability and smaller influence on mechanical and dielectric properties (storage in water at 23 °C).

Ultramid® Advanced T2000

COMPOUND PORTFOLIO TAILORED FOR SPECIFIC E&E REQUIREMENTS

With Ultramid® Advanced T2000, BASF is further expanding its PPA product portfolio. Initially, BASF offers different grades for metal replacement over a broad temperature range. The BASF product development and application specialists are dedicated to continuously developing this portfolio with further customized compounds to extend and improve the products' fit and performance according to customer demands.

The initial portfolio consists of the following compounds:

- Standard and high heat-stabilized, glass-fiber reinforced grades with reinforcement levels of 30 % to 50 % to provide a broad range of stiffness, strength and toughness, available both as uncolored and laser-markable black
- Reinforced grades with improved impact resistance, with e.g. 30 % glass fiber reinforcement
- A special range of flame retardant and glass-fiber reinforced grades with 30 % to 40 % glass fiber reinforcement and with UL 94 V-0 rating available for all colors

All grades are suitable for processing by injection molding.

Several other specialty grades are under development. Please contact our sales or technical team for a recommendation of the product that suits your specific application.



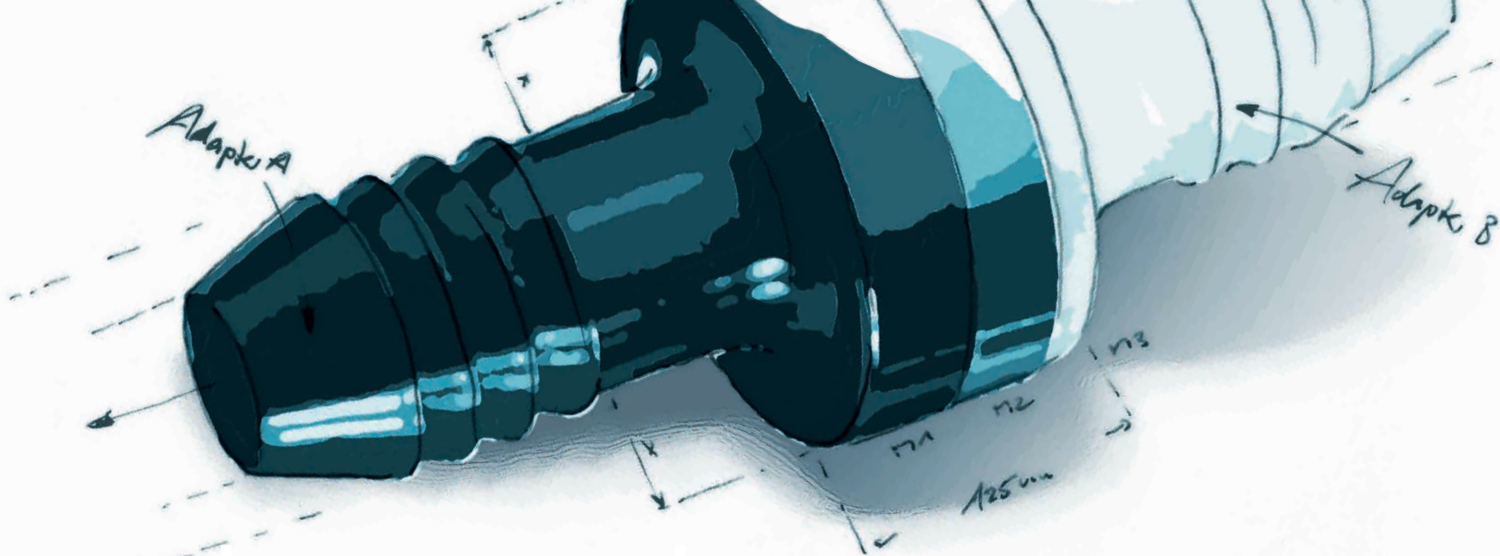

Family	Grade	Product description
Glass-fiber reinforced	Ultramid® Advanced T2000 HG6 to G10	30 to 50 % GF, medium heat stabilization (H type), available in uncolored and laser-markable black
	Ultramid® Advanced T2000 ZG6	30 % GF, medium heat stabilization (H type), with improved impact strength, available in laser-markable black
	Ultramid® Advanced T2000 WG6 to G10	30 to 50 % GF, high heat stabilization (W type), available in uncolored and laser-markable black
Glass-fiber reinforced and flame retardant	Ultramid® Advanced T2040 G6 LS black	30 % GF, medium heat stabilization, flame retardant without halogens, fulfilling UL 94-V0 rating, high flowability
	Ultramid® Advanced T2040 G8 LS black	40 % GF, medium heat stabilization, flame retardant without halogens, UL 94-V0 rating, high flowability

Ultramid® Advanced T2000

FOR THE ELECTRICAL AND ELECTRONICS INDUSTRY

Ultramid® Advanced T2000 shows an excellent mechanical and dielectric performance across a broad temperature range. These features can be combined with required flame-retardant properties. This makes them the material of choice for a lot of new E&E applications.

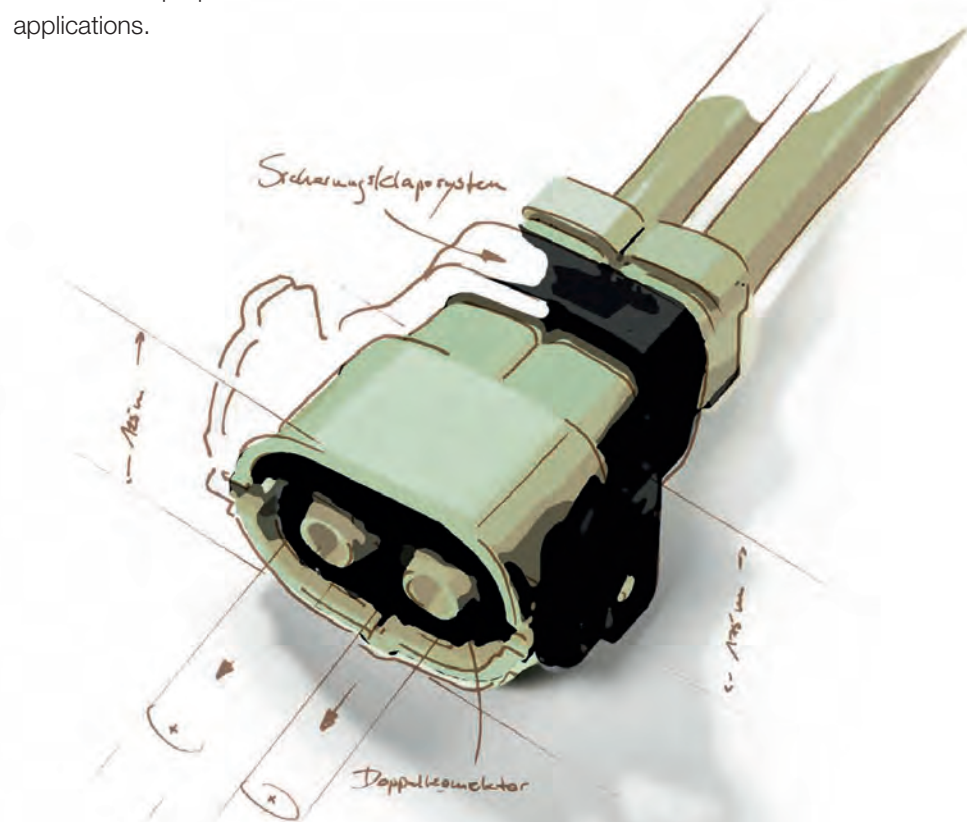

Structural laptop parts

Ultramid® Advanced T2000 displays high stiffness and strength, excellent heat resistance and low warpage. These properties make it suitable for the production of structural laptop parts. It offers the benefit of lighter weight compared to metal and further potential for wall thickness reduction. With its high flowability in injection molding, Ultramid® Advanced T2000 enables thin-wall design and good surface quality.

Connectors

Ultramid® Advanced T2000 is the best choice when it comes to excellent strength and stiffness at the very high temperatures which are typical for lead-free soldering. At the same time, it offers good processability also with rather delicate flame-retardant components.

Switches and miniature circuit breakers

Ultramid® Advanced T2000 is the ideal material for electrical and electronic devices that demand self-extinguishing properties as well as high stiffness and dimensional accuracy. These properties help the components to retain their shape and structure when exposed to repeated short-term high-heat conditions that commonly occur in industrial soldering processes. The new BASF PPA enhances part integrity: structures made of Ultramid®

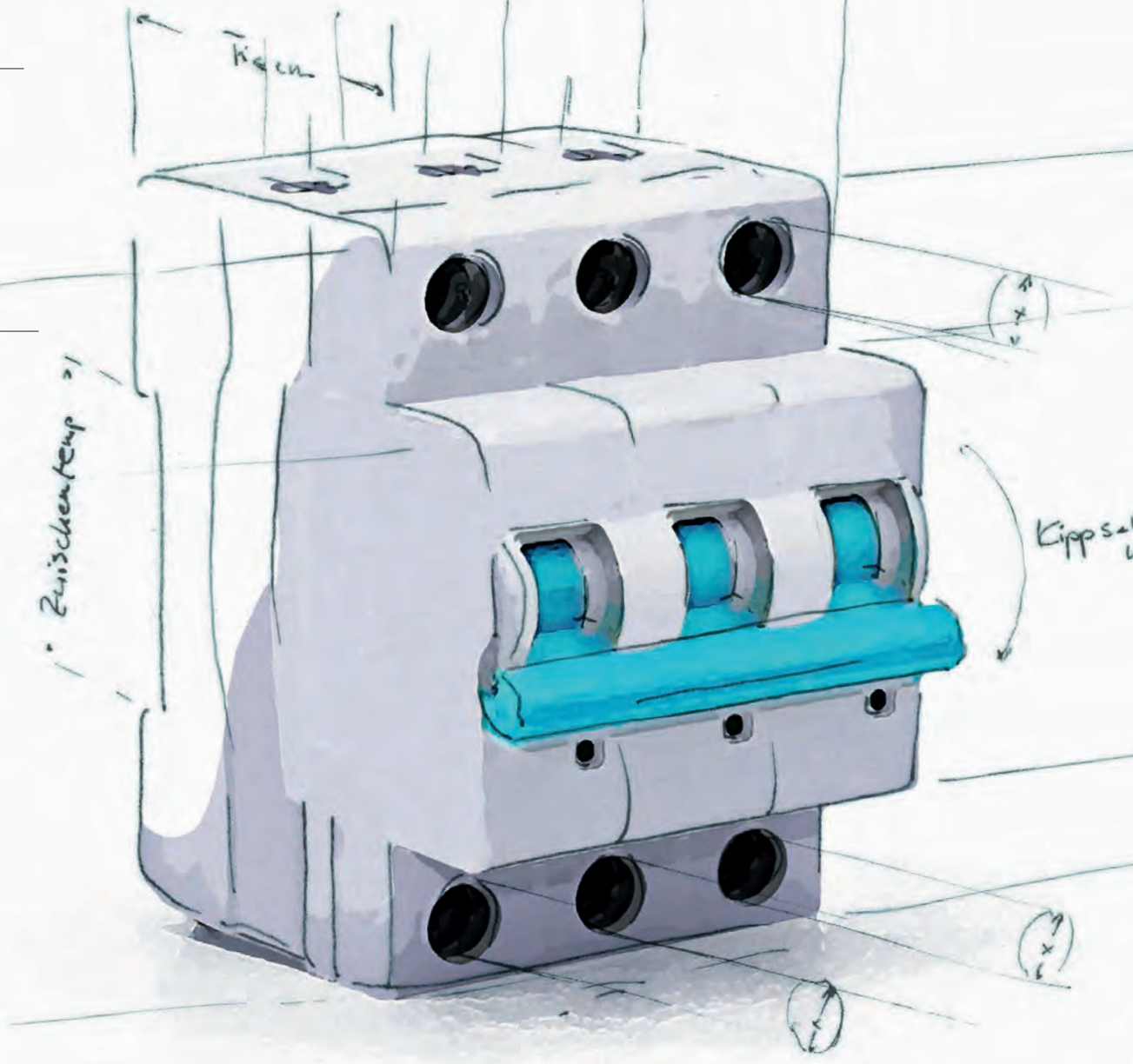

Advanced T2000 resist melting when exposed to transient extreme heat and are resistant to external mechanical shock. In this way, Ultramid® Advanced T2000 is an interesting alternative to thermosets for these applications.

Component - Plastics

E41871

Guide Information

BASF SE

Performance Materials Europe, E-PME/NQ - H201, Ludwigshafen 67056 DE

Advanced T2040 G6 (t)

Color	Min. Thk. (mm)	Flame Class	HWI	HAI	RTI Elec.	RTI Imp.	RTI Str.
ALL	0.40	V-0	0	0	65	65	65
	0.75	V-0	0	0	65	65	65
	1.5	V-0	0	0	65	65	65
	3.0	V-0	0	0	65	65	65

Fig. 7: UL card registrations are in process. Registrations will be uploaded to the UL database and viewable by the public upon completion.

Ultramid® Advanced T2000

FOR THE AUTOMOTIVE AND TRANSPORTATION INDUSTRY

Ultramid® Advanced T2000 glass-fiber reinforced grades offer the optimal combination of easy processing with high strength even at temperatures above the glass transition point. This makes them a versatile candidate for metal replacement.

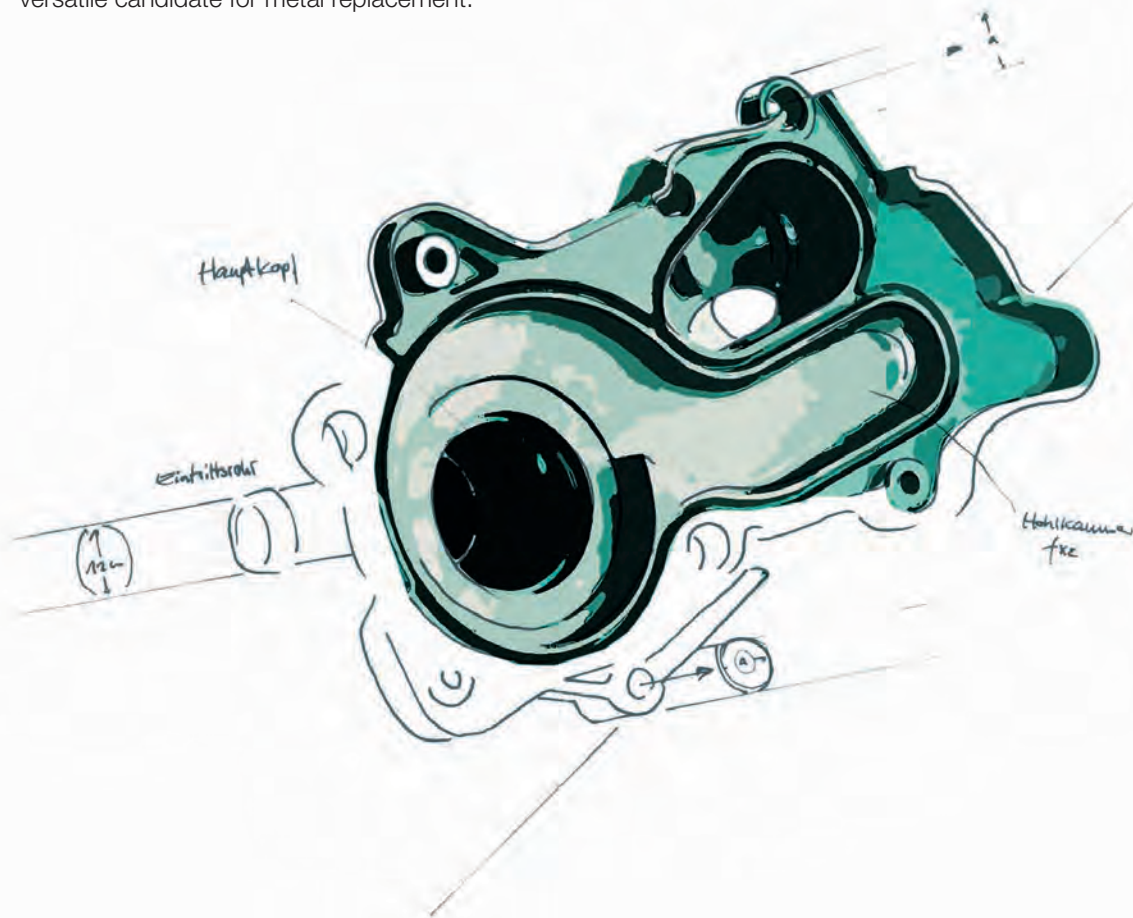

Water outlet valves and water pumps

Rising application temperatures can be challenging for standard engineering plastics such as PA 6 or PA 66 and even limit the lifetime of parts when in contact with water or moisture, hot coolants or other automotive fluids. Ultramid® Advanced T2000 is a reliable metal replacement: It combines mild processing conditions with excellent mechanical properties in presence of automotive fluids (e.g. cleaners, road salts) over a broad range of operating temperatures.

Fuel system components (e.g. quick connectors, sensors)

Ultramid® Advanced T2000 exhibits good resistance to all common automotive media such as coolants, fuels, oils and lubricants. The good flowability allows for a broad processing window.

Actuators and actuator housings (e.g. waste gates)

Ultramid® Advanced T2000 shows constant mechanical performance and dimensional stability over a broad temperature range. Especially the high stiffness and strength at elevated temperatures lead to longer life times of parts due to excellent fatigue and creep resistance.

Transmission sensors

Ultramid® Advanced T2000 exhibits good heat resistance and chemical resistance for sensors in the transmission system.

Clutch parts

Ultramid® Advanced T2000 features the high levels of stiffness and strength required for highly loaded parts in the clutch system.

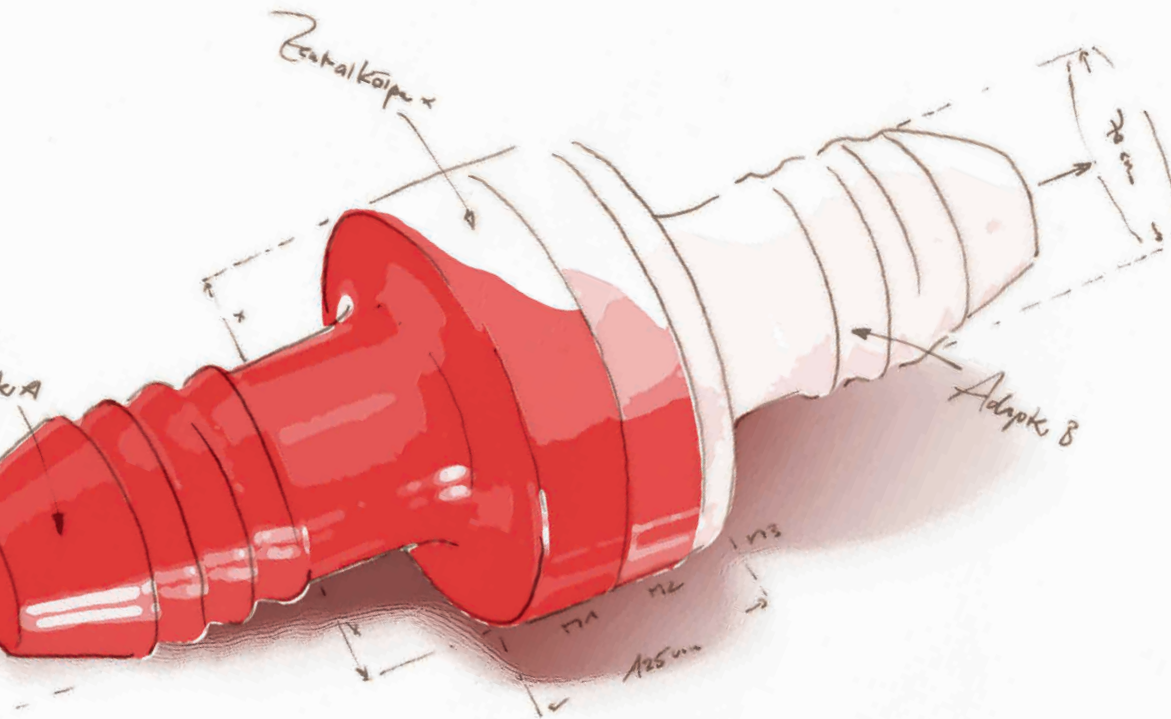

Ultramid® Advanced T2000 – EASY PROCESSING

Ultramid® Advanced T2000 is a material with a high melting temperature of about 310 °C and a high glass transition temperature. Processing with common injection molding machines is possible, provided that optimum processing conditions prevail: the melt temperature should ideally be 320 °C and the mold temperature 140 °C.

Ultramid® Advanced T2000 can be processed with open nozzles and needle valve nozzles. The moisture content of the resin before processing should be lower than 0.05 %.

A comparison of the flowability of different flame-retardant Ultramid® grades processed under appropriate standard processing conditions for each grade is shown in fig. 8. Equal injection speeds and injection pressures result in different flow lengths. The Ultramid® Advanced grades show a significantly higher flowability compared to other high-temperature polyamides.

Detailed processing recommendations are available to enable an optimum injection molding process. For more information please get in contact with your BASF representative.

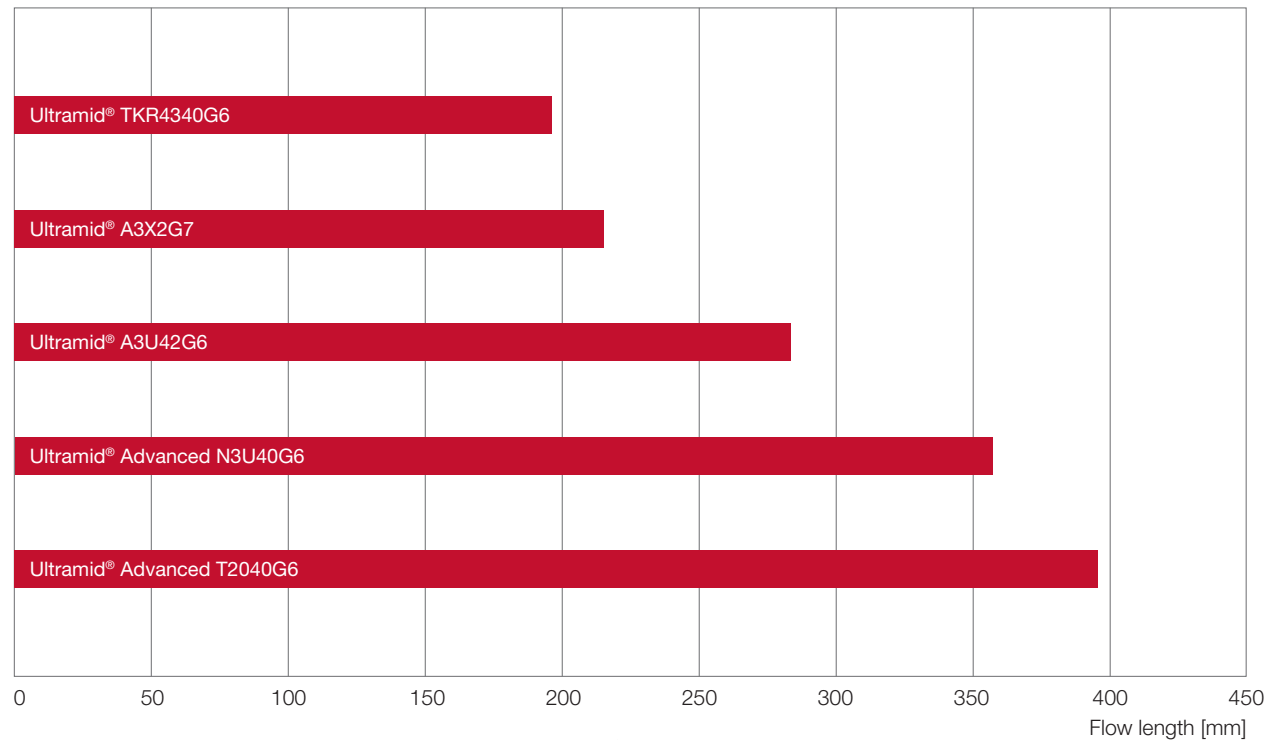

Fig. 8: Maximum flow lengths of different flame-retardant Ultramid® grades in a spiral flow mold with a wall thickness of 1.5 mm.

Ultramid® Advanced T2000 – VERSATILE POST-PROCESSING

Plastic parts made of Ultramid® Advanced T2000 can be further processed using many different methods:

- They can be welded to complex structural elements using rotational, vibration or laser welding.
- Most grades are laser markable: Combined with a smooth surface, the markings feature high contrast (fig. 9).

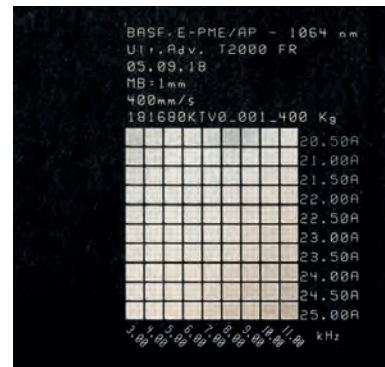
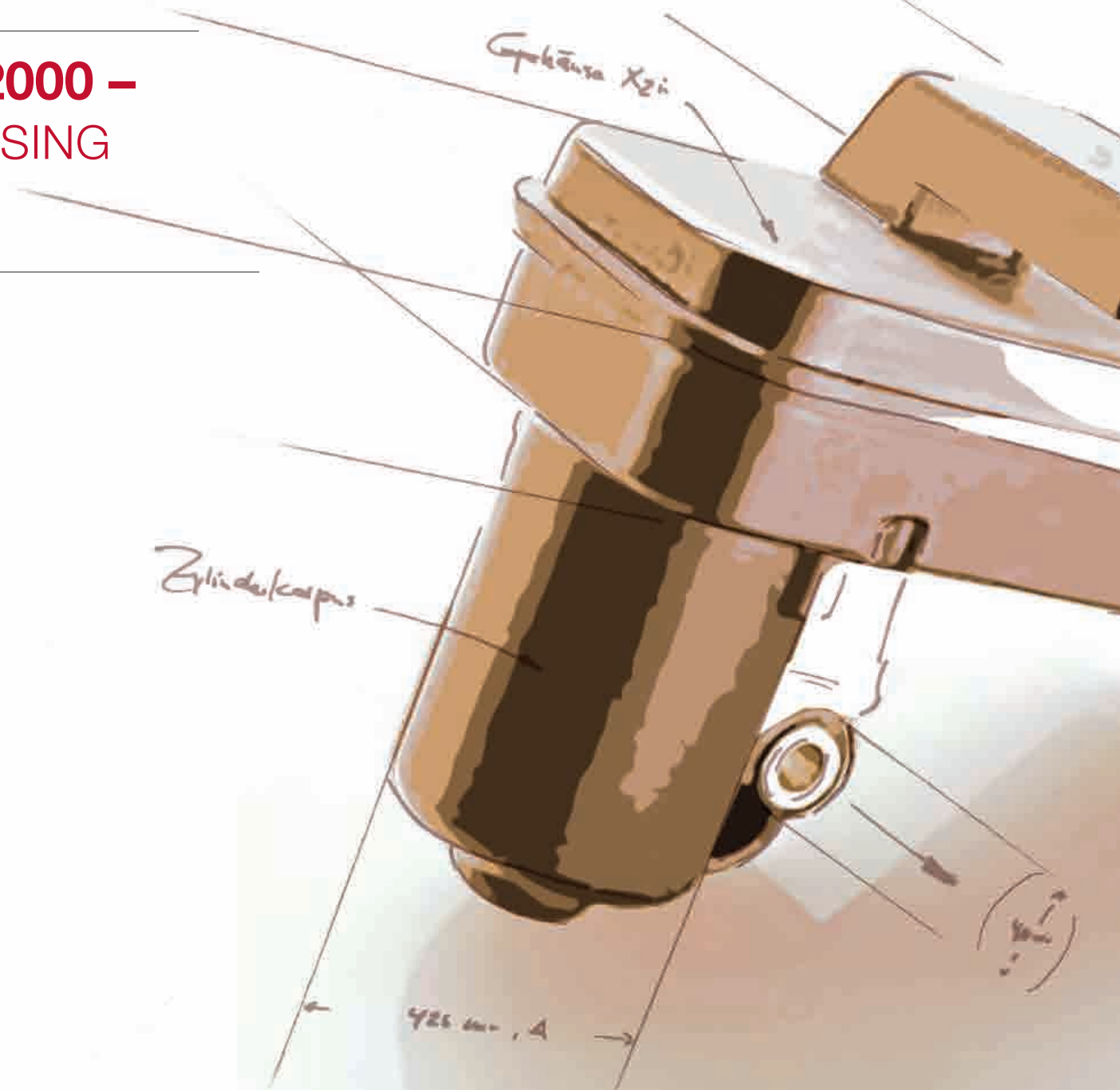

Fig 9: With Ultramid® Advanced T2000, parts can be excellently laser-marked.



Ultramid® Advanced T2000 – PRECISE PART DESIGN WITH ULTRASIM®

BASF's simulation tool Ultrasmim® is used in the design of parts for all industries. Examples are found in automotive and mechanical engineering, in construction, in power tools and household appliances, and in parts for the sports and leisure sectors.

With customized models, BASF has further developed the calculation tool in such a way that parts made of Ultramid® Advanced T2000 can also be simulated. Using Ultrasmim®, the physical behavior of the part can be predicted on the basis of manufacturing parameters, fiber anisotropy and load direction or speed. The mathematical part optimization can furthermore provide the best possible design under the given conditions.

Ultrasmim® is therefore a unique tool for optimizing customer parts at a very early stage so that they are able to handle highest loads. With these precise predictions, costs and time associated with prototypes or extensive mold corrections can be minimized.

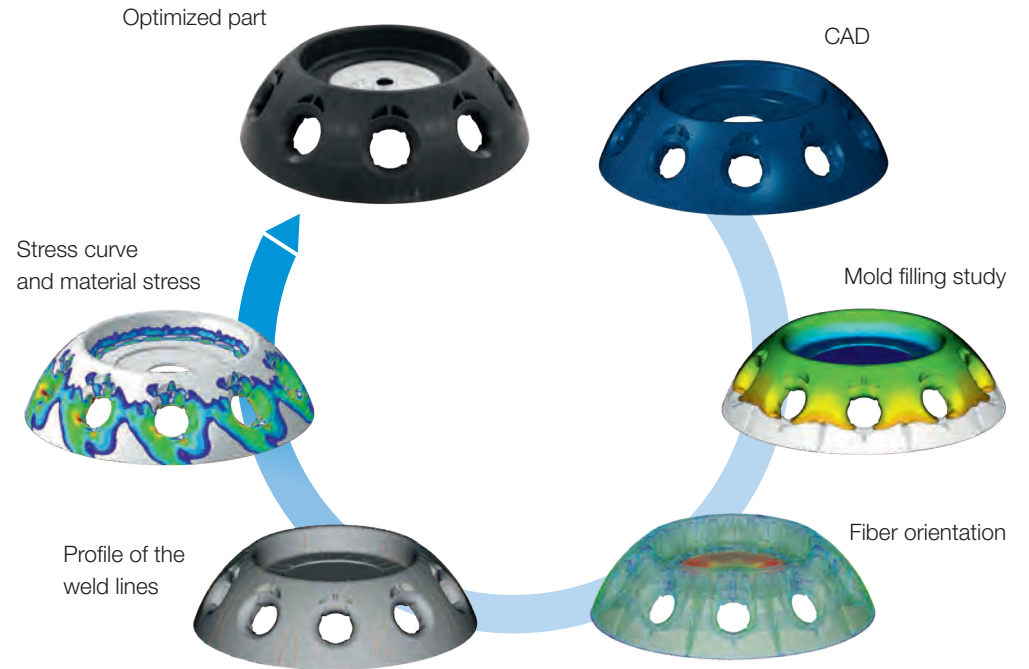
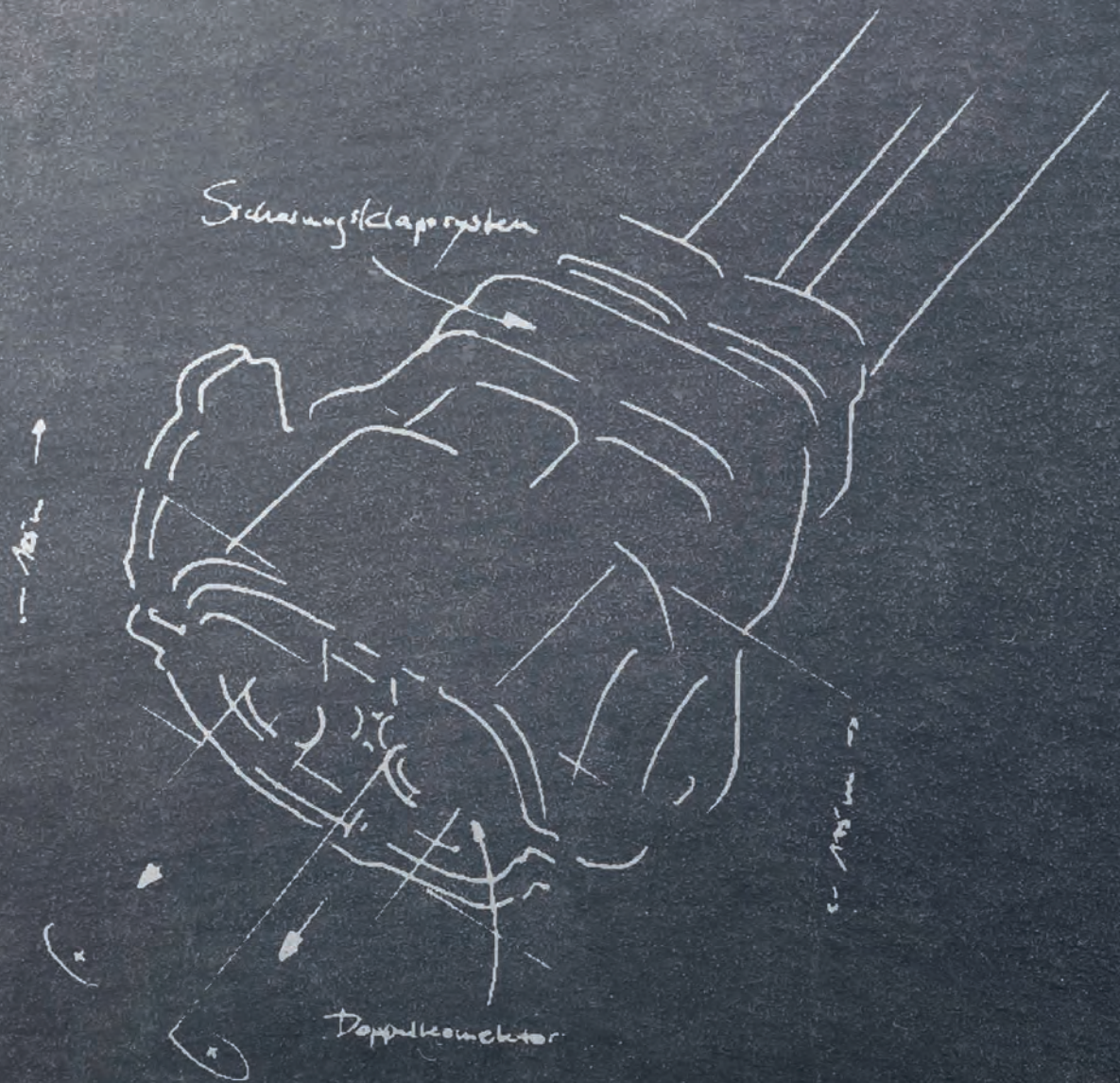

Fig. 10: Process of designing parts with the BASF simulation tool Ultrasmim®

**Get connected
to us to plug
into Ultramid®
Advanced T2000!**

ultraplaste.infopoint@basf.com
+49 621 60-78780



**Further information on Ultramid® Advanced T2000
can be found on the internet:**

www.ultramid-advanced-t2000.basf.com

For more possibilities with BASF's PPAs, please refer to the brochures
on Ultramid® Advanced N and Ultramid® Advanced T1000.

Or go to:

www.ultramid-advanced-n.basf.com

www.ultramid-advanced-t1000.basf.com

Request of brochures:

PM/K, F204

Fax: +49 621 60-49497

**If you have technical questions on the products,
please contact the Ultra-Infopoint:**



**Ultra
Infopoint**

+49 621 60-78780
ultraplaste.infopoint@basf.com

Note

The data contained in this publication are based on our current knowledge and experience. In view of the many factors that may affect processing and application of our product, these data do not relieve processors from carrying out own investigations and tests; neither do these data imply any guarantee of certain properties, nor the suitability of the product for a specific purpose. Any descriptions, drawings, photographs, data, proportions, weights etc. given herein may change without prior information and do not constitute the agreed contractual quality of the product. It is the responsibility of the recipient of our products to ensure that any proprietary rights and existing laws and legislation are observed. (April 2019)